

Columbia DIY Ventilator Design Challenge

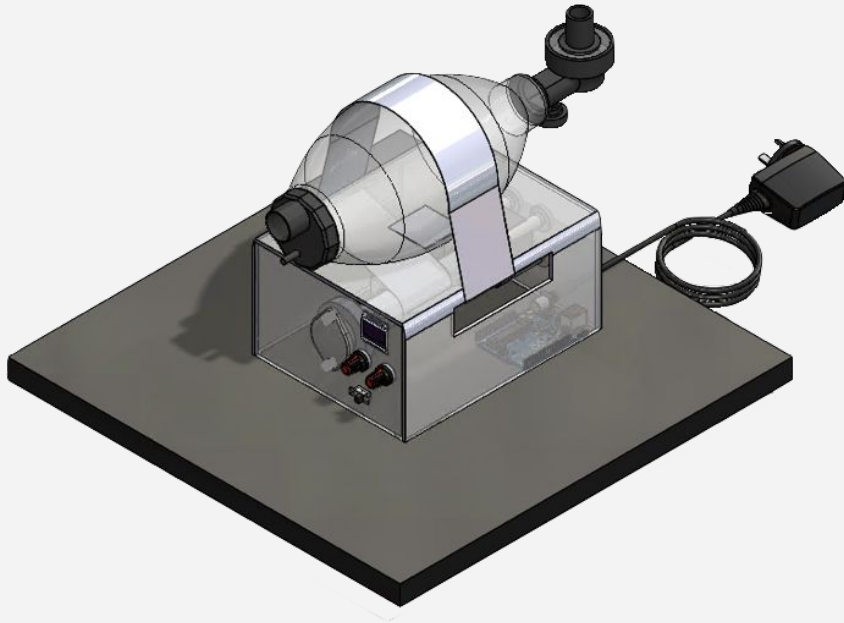

Shinya Kondo (ME '20),

Lynn Bi (BME '20),

Alyssa Hwang (CS '20),

Haley So (EE '20),

Columbia University, School of Engineering and Applied Science

Design Overview

Our design is a simple, compact, low-cost, easy-to-use, and easy-to-build ventilator that inflates and deflates an Ambu Bag at specific amplitudes and rates. The system can be built with readily available, low-cost materials in an emergency timeframe. Using highly interchangeable parts is emphasized--users may follow our exact specifications or replace the box, belt, etc. with cheaper or more accessible materials.

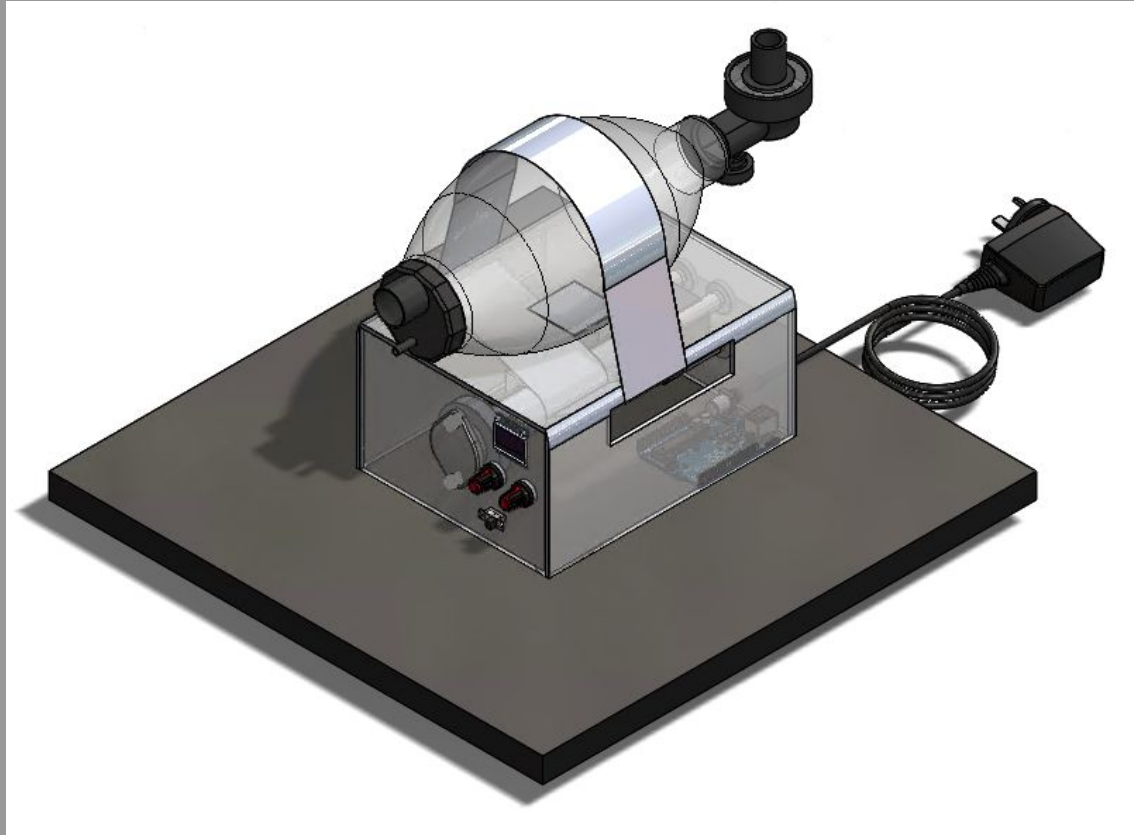

Basic Specifications

- Frequency: 10 - 30 cycles/min
- Maximum force that can be applied to the bag:
10 lb-f
- Maximum pressure in bag: 30 cm H₂O
- Amplitude: 1-6 inches
- Total number of parts: 20
- Total cost of parts: \$152.09
- List of tools needed for construction:
screwdriver
- Estimated # hours for construction: 3 hrs

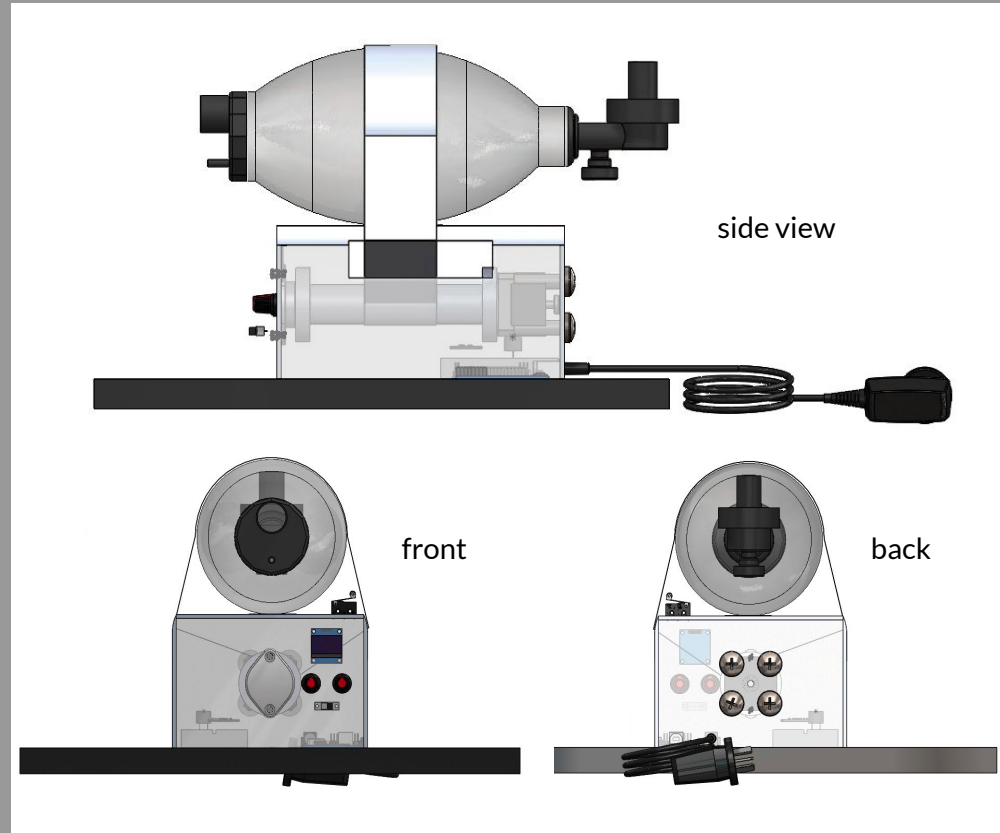

Exploded View

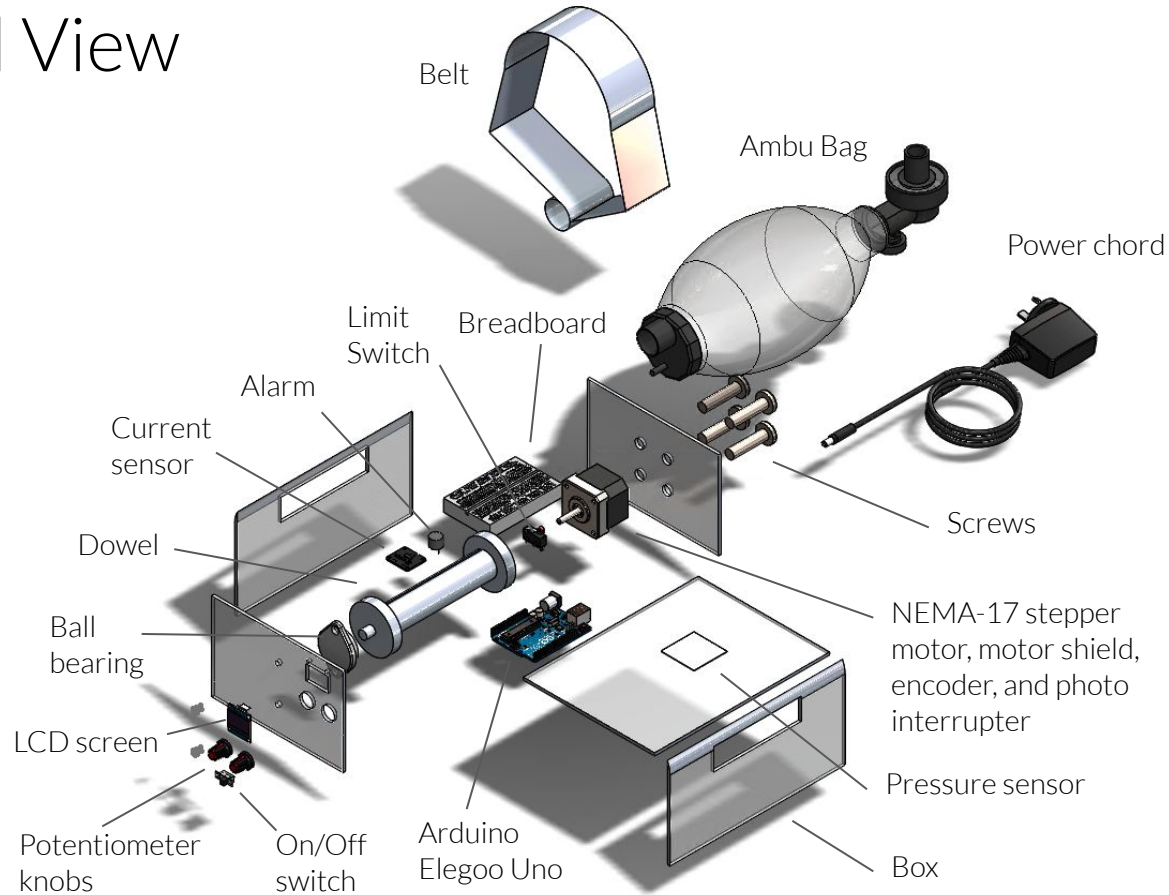

Mechanism for Inflation and Deflation of Ambu Bag

[View animation here!](#)

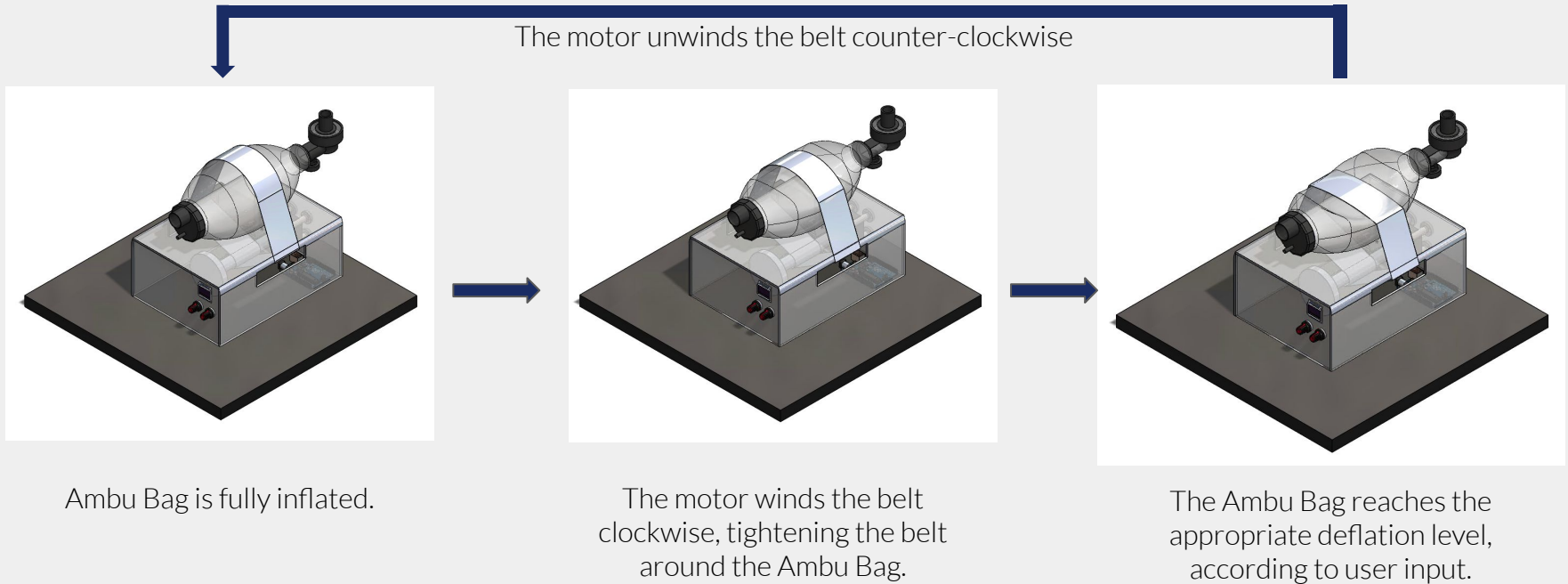

Sensor Descriptions and Safety Measures

Setting limits of motion:

- In the **Arduino**, we will be able to set the limits of compression to control amplitude range and frequency of compression.
- We also have the **motor encoder** and **photo interrupter** to measure the actual position of the motor for additional feedback to ensure we have calibrated correctly.

Detecting a sudden drop in pressure:

- Through our **current sensor**, we will be able to detect if the current drawn by the motor decreases suddenly, indicating there has been a drop in pressure.
- A redundancy mechanism is provided by the **pressure sensor**, which measures the pressure applied to the Ambu Bag at the base.
- Additional safety measures are provided by the **limit switch**. If the *limit switch* is hit, we know the motor has wound the belt too far, exerting too much pressure on the Ambu Bag.
- System failures will result in an **alarm** being sounded and a warning message displayed on the **GUI**.

State Machine

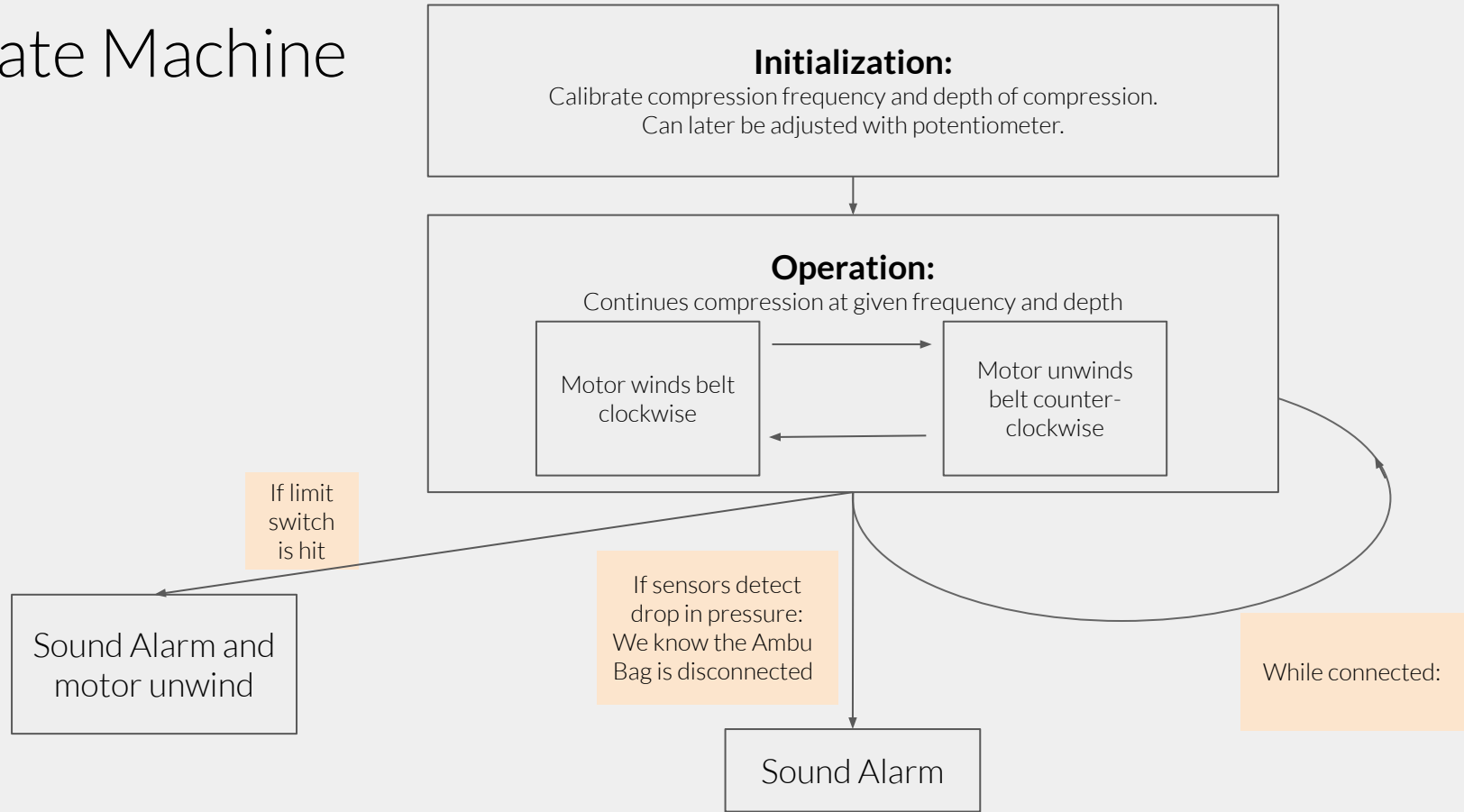

Hardware System/Block Diagram

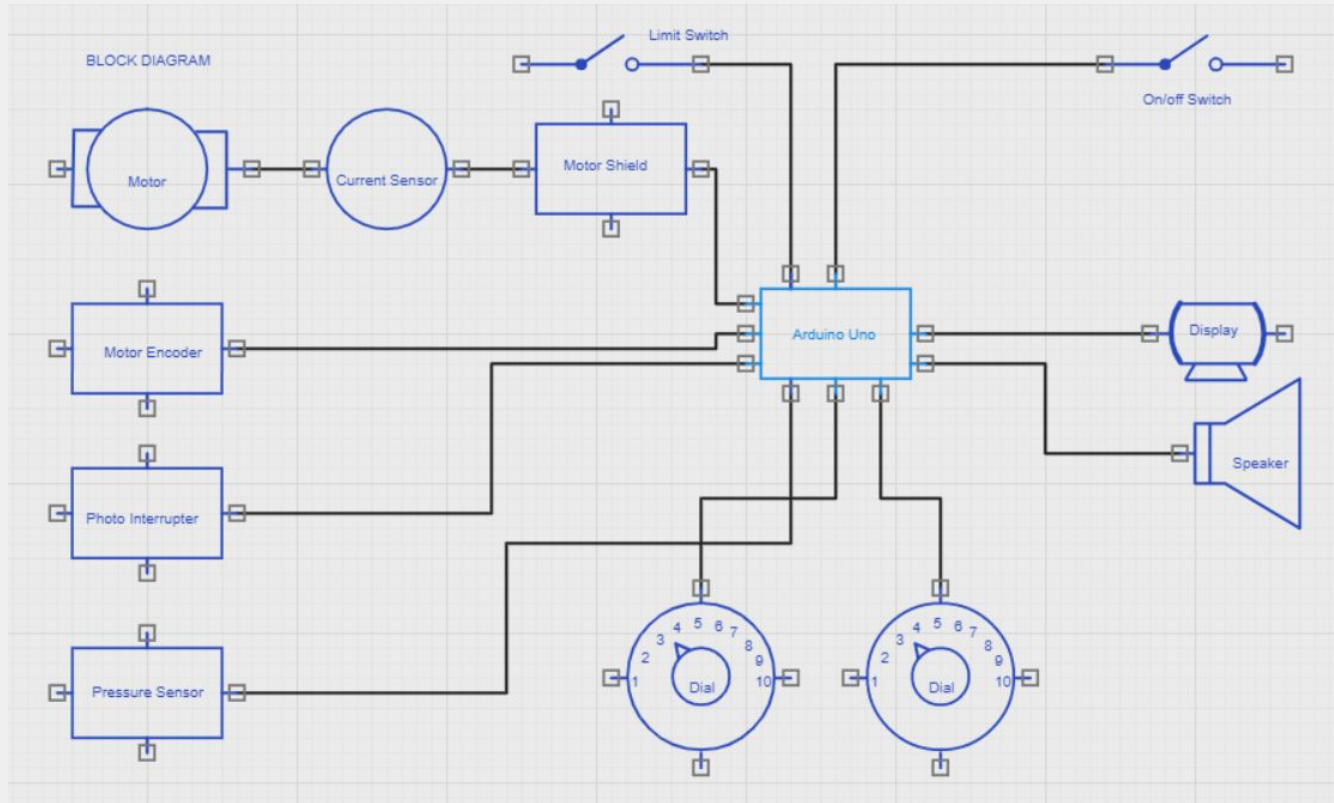

GUI for Initialization

Automatic Ambu Bag Compressor

Calibrate

Settings

Operate



Calibrate

At this stage, we will calibrate the depth of compression with the rotation of the motor. Press START to start the compression. Press STOP when the belt has compressed the Ambu Bag by one inch. Press SAVE to save that trial or REDO to run the trial again. The process will repeat until it has three saved trials. Press EXIT to go back to the home screen.

Begin Trial 2

START



STOP

SAVE

REDO

✔ Trial 1
▶ Trial 2
Trial 3

GUI for Operation



  

Settings

Calibration status: 

Compression depth (inches):

Frequency (compressions/minute):

  

Operate

Depth:

Freq:

Volume

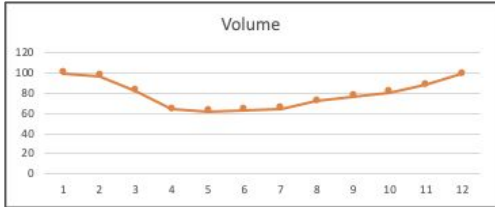

Cycle	Volume
1	100
2	95
3	85
4	65
5	60
6	62
7	65
8	70
9	75
10	80
11	85
12	100

Pressure

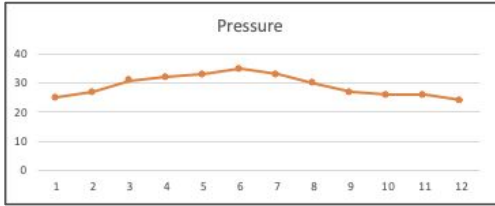

Cycle	Pressure
1	25
2	28
3	32
4	33
5	34
6	35
7	33
8	30
9	28
10	26
11	25
12	24

Parts List

Component	Purpose	#	Cost per unit	Total Cost
Arduino Elegoo Uno	Serves as our microcontroller and to set frequency of pumping and the limit to how far to compress the ambu bag.	1	14	14
Stepper Motor Shield	Shield for driving motors	1	19.95	19.95
Stepper Motor	Motor to wind up belt to compress the ambu bag	1	14	14
Current Sensor	Sense how much resistance there is in compressing the bag so we know if there is an disconnected part if for example there is a significant decrease in resistance when compressing the bag	1	8.95	8.95
Pressure sensor	Measure the pressure being applied by the bag to the base	1	8.95	8.95
Alarm/buzzer	Buzzer sounds when pressure is not as expected, indicating a unconnected component	1	0.95	0.95
Motor Encoder	To encode rotations to see if our theoretical matches the actual speed	1	0.95	0.95
Photo interrupter	Paired with the motor encoder, measures speed of motor	1	2.95	2.95
Limit switches	Safety check: if the bag gets compressed too much, it will hit the limit switch, and the motor will unwind	1	0.51	0.51
Breadboard	To connect all the components	1	5.95	5.95
OLED display	Displays current settings like frequency	1	12.5	12.5
Potentiometers. Knobs	Changes frequency of compressions (or can be done on arduino)	2	0.79	1.58
Wall adapter	For power from the wall	1	8	8
Toggle switch	To turn on on off mechanism	1	3	3
Box	To encase the electrical components,	1	5	5
Dowel	To wind and unwind the belt	1	0	0
Mounted Ball Bearing	To stabilize the dowel	1	14.9	14.9
Belt	Seatbelt (or a belt composed of a material with a high Young's Modulus)	1	0	0
Ambu Bag		1	29.95	29.95
			Total	152.09

Interchangeability

Our emergency ventilator is designed with parts that may be exchanged with commonly found items. Our software will guide the user through a calibration process that will adjust the motor to support a range of amplitude according to the size of the box. The users may also construct the ventilator according to our specifications, which would allow them to use it without calibration--this requires access to a 3D printer to create the dowel attached to the motor. Our flexibility in design allows for a wide range of materials and decrease in cost.

Users must buy the Arduino and sensors we specify. In addition to Users may choose their own boxes, belt, and dowels. The motor may be replaced by the motor found in a power drill. The belt can be constructed with a durable, inelastic strip of cloth with high Young's modulus; we suggest a seatbelt or backpack strap. Our design focused on cost-effectiveness and accessibility of materials.

Caveats

This design focuses on DIY-ability and features several interchangeable parts. We purposefully did this to allow users to decrease costs and increase accessibility--users are not restricted to our specific materials or measurements to create a functioning automatic ventilator. This does, however, come with the disadvantage of less standardization and higher risk of human error when constructing the device. We hope that the simplicity of our device coupled with the built-in calibration software will minimize these risks.

Requested Funding

We are requesting \$2,000 for our initial prototyping. This will cover the parts listed in the parts list, multiples of each for testing, variations of parts, as well as any machinery required for the prototype and build (a 3D printer, power supply).

References and Acknowledgments

We have referenced the following sources in order to design our solution:

- MIT Emergency Ventilator (E-Vent) Project: <https://e-vent.mit.edu>
- Ambu-Bag: <https://www.ambu.com/emergency-care-and-training/clinical-evidence/ambu-resuscitator>

Thank you to Dr. David Vallancourt, Dr. Yevgeniy Yesilevskiy and Chris See for giving us advice and feedback on our design, and thank you to the Columbia Engineering Department for hosting this amazing challenge.